

Separate catalog available

RC-0310S/D-SE

Offering speed, reliability and energy savings with a wide range of scalable functions

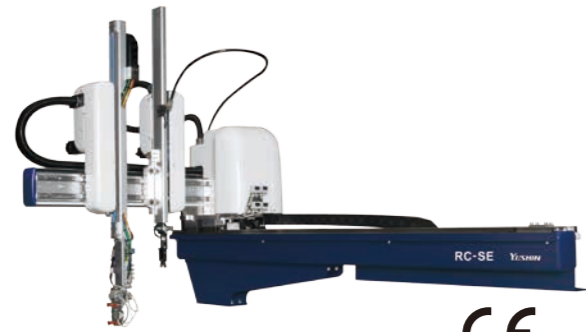

For CE supported languages, please contact our sales department.

Clamping force 30 - 100 tf

Vibration control

Power-saving

All-axis servo-driven

Running Cost Reduction Compressed Air Economizing Tool Smart ECO Vacuum

Yushin has refined our unique ECO Vacuum technology to reduce compressed air consumption even further. Smart ECO Vacuum monitors vacuum pressure continuously to optimize suction timing. As a result, robot air consumption can be economized by as much as 78%, which can lead to lower electricity costs for air compressors and reduced capital expenditures.

Standard Specifications

Power supply		Drive method		Controller model		Working air pressure		Flip angle		
1-phase 200 VAC/220 VAC (50/60 Hz)		Digital servo motor 3/5-axis		E-touch II		0.49 MPa		90°		
Model	Power consumption	Traverse stroke [mm]	Kick stroke [mm]		Vertical stroke [mm]		Air consumption [NL/cycle]	Payload [kg]	Noise [dBA]	Target IMM clamp capacity [tf]
			Main arm	Sub arm	Main arm	Sub arm				
RC-0310S-SE	0.9 kVA 1-phase 200 VAC 4.3 A	1400 (1700)	500	—	600 (700)	—	4.0 Smart ECO Vacuum OFF	3 (5)	76.1	30-100
RC-0310D-SE	1.1 kVA 1-phase 200 VAC 5.5 A		450	450	650 (750)	650 (750)	1.2 Smart ECO Vacuum ON			

S type : Robot is equipped with main arm only. D type : Robot is equipped with main arm and sub arm.
() : Modified stroke () : Increased maximum payload
Payload includes the end-of-arm tool.

Rear (Non-operator) Side Discharge Direction [mm]

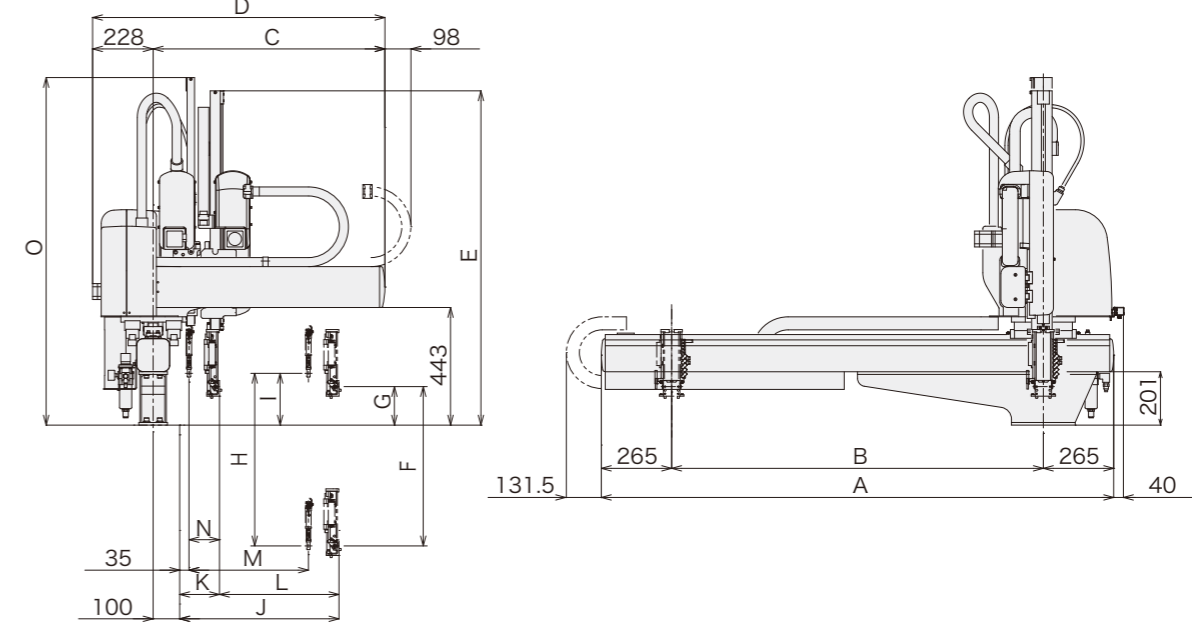

Operator Side Discharge Direction [mm]

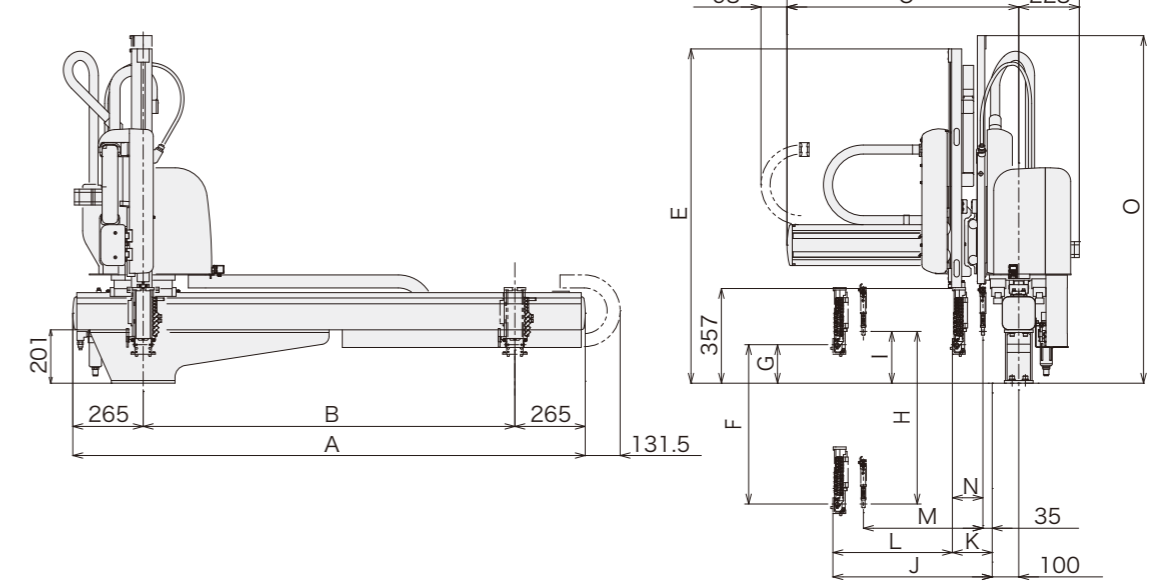

[mm]

Model	A	B	C	D	E	F	G	H	I	J	K	L	M	N	O
RC-0310S-SE	1930	1400 (1700)	873	1101	1259	600	145	—	—	600	100	500	—	—	—
RC-0310D-SE	2230							650	195		150	450	450	115	1309

() : Modified stroke

Controller [mm]

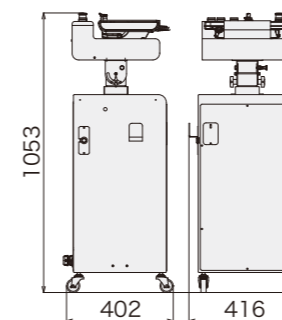

All-Axis Servo Driven Type

Swing Type

Side Entry Type

For Vertical Molding Machine

Stock System

Product Series Guide [P11]

All-Axis Servo Driven Type Take-Out Robot